

SENSORS ON 3-D DIGITALIZATION

Tahaseen Jahan, Financial Chair, IEEE VEC SB

Department of Electronics and Communication Engineering

Vaagdevi Engineering College

Bollikunta, Warangal, Telangana, 506005, India

Email ID: mr099704@gmail.com

Date : 12th October 2019

Abstract: Digital 3D imaging can benefit from advances in VLSI technology in order to accelerate its deployment in many fields like visual communication and industrial automation. High-resolution 3D images can be acquired using laser-based vision systems. With this approach, the 3D information becomes relatively insensitive to background illumination and surface texture. Complete images of visible surfaces that are rather featureless to the human eye or a video camera can be generated. Intelligent digitizers will be capable of measuring accurately and simultaneously colour and 3D.



1 INTRODUCTION

Digital 3D imaging can benefit from advances in VLSI technology in order to accelerate its development in many fields like visual communication and industrial automation. High-resolution 3D images can be acquired using laser-based vision systems. With this approach, the 3D information becomes relatively insensitive to background illumination and surface texture. Complete images of visible surfaces that are rather featureless to the human eye or a video camera can be generated. Intelligent digitizers will be capable of measuring accurately and simultaneously color and 3D.

1.1 COLOUR 3D IMAGING TECHNOLOGY

Machine vision involves the analysis of the properties of the luminous flux reflected or radiated by objects. To recover the geometrical structures of these objects, either to recognize or to measure their dimension, two basic vision strategies are available. Passive vision, attempts to analyze the structure of the scene under ambient light. Stereoscopic vision is a passive optical technique. The basic idea is that two or more digital images are taken from known locations. The images are then

processed to find the correlations between them. As soon as matching points are identified, the geometry can be computed.

Active vision attempts to reduce the ambiguity of scene analysis by structuring the way in which images are formed. Sensors that capitalize on active vision can resolve most of the ambiguities found with two-dimensional imaging systems. LIDAR based or triangulation-based laser range cameras are examples of active vision technique. One digital 3D imaging system based on optical triangulation were developed and demonstrated.

1.2 AUTOSYNCHRONIZED SCANNER

The auto-synchronized scanner, depicted schematically on Figure 1, can provide registered range and color data of visible surfaces. A 3D surface map is captured by scanning a laser spot onto a scene, collecting the reflected laser light, and finally focusing the beam onto a linear laser spot sensor. Geometric and photometric corrections of the raw data give two images in perfect registration: one with x, y, z co-ordinates and a second with reflectance data. The laser beam composed of multiple visible wavelengths is used for the purpose of measuring the color map of a scene (reflectance map).

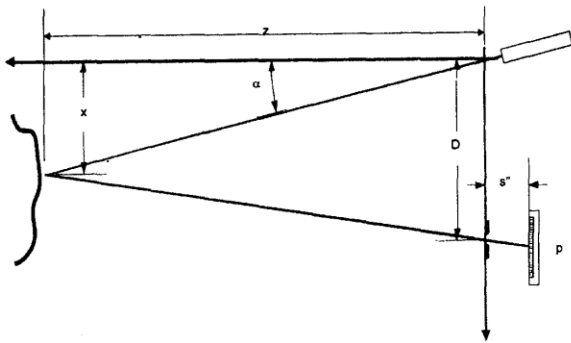

Figure 1: auto synchronized scanner

ADVANTAGE

- Triangulation is the most precise method of 3D.

LIMITATION

- Increasing the accuracy increases the triangulation distance. The larger the triangulation distance, the more shadows appear on the scanning object and the scanning head must be made larger.

2 SENSORS FOR 3D IMAGING

The sensors used in the auto synchronized scanner include

2.1 SYNCHRONIZATION CIRCUIT BASED UPON DUAL PHOTOCELLS

This sensor ensures the stability and the repeatability of range measurements in environment with varying temperature. Discrete implementations of the so-called synchronization circuits have posed many problems in the past. A monolithic version of an improved circuit has been built to alleviate those problems.

2.2 LASER SPOT POSITION MEASUREMENT SENSORS

High-resolution 3D images can be acquired using laser-based vision systems. With this approach, the 3D information becomes relatively insensitive to background illumination and surface texture. Complete images of visible surfaces that are rather featureless to the human eye or a video camera can be generated.

2.3 POSITION SENSITIVE DETECTORS

Many devices have been built or considered in the past for measuring the position of a laser spot more efficiently. One method of position detection uses a video camera to capture an image of an object electronically. Image processing techniques are then used to determine the location of the object. For

situations requiring the location of a light source on a plane, a position sensitive detector (PSD) offers the potential for better resolution at a lower system cost. The PSD is a precision semiconductor optical sensor which produces output currents related to the “centre of mass” of light incident on the surface of the device. While several design variations exist for PSDs, the basic device can be described as a large area silicon p-i-n photo detector. The detectors can be available in single axis and dual axis models.

2.4 DUAL AXIS PSD

This particular PSD is a five terminal device bounded by four collection surfaces; one terminal is connected to each collection surface and one provides a common return. Photocurrent is generated by light which falls on the active area of the PSD will be collected by these four perimeter electrodes.

The amount of current flowing between each perimeter terminal and the common return is related to the proximity of the centre of mass of the incident light spot to each collection surface. The difference between the “up” current and the “down” current is proportional to the Y-axis position of the light spot. Similarly, the “right” current minus the “left” current gives the X-axis position. The designations “up,” “down,” “right” and “left” are arbitrary; the device may be operated in any relative spatial orientation.

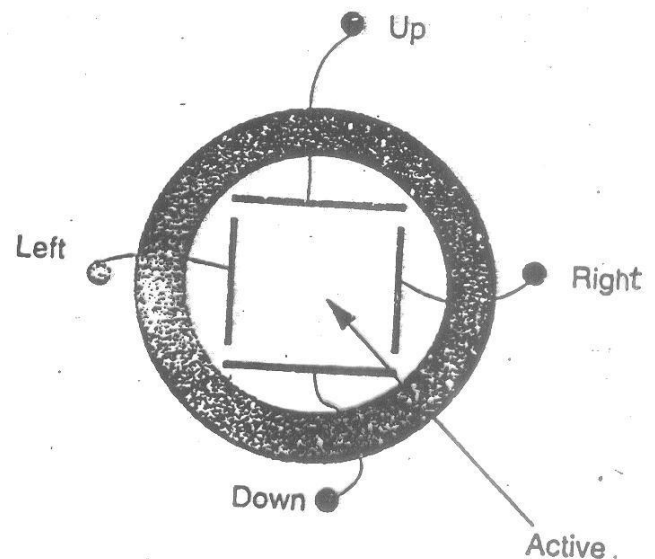

Figure 2: A typical dual axis PSD

3 LASER SENSORS FOR 3D IMAGING

The state of the art in laser spot position sensing methods can be divided into two broad classes according to the way the spot position is sensed. Among those, one finds continuous response position sensitive detectors (CRPSD) and discrete response position sensitive detectors (DRPSD).

3.1 CONTINUOUS RESPONSE POSITION SENSITIVE DETECTORS (CRPSD)

The category CRPSD includes lateral effect photodiode.

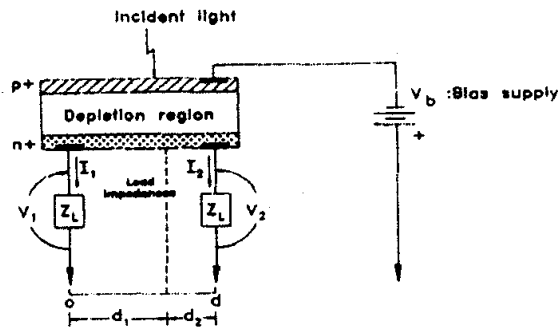

Figure3: Basic structure of a single-axis lateral effect photodiode

Figure illustrates the basic structure of a p-n type single axis lateral effect photodiode. Carriers are produced by light impinging on the device are separated in the depletion region and distributed to the two sensing electrodes according to the Ohm’s law. Assuming equal impedances, the electrode that is the farthest from the centroid of the light distribution collects the least current. The normalized position of the centroid when the light intensity fluctuates is given by $P = \frac{I_2 - I_1}{I_1 + I_2}$.

The actual position on the detector is found by multiplying P by d/2, where d is the distance between the two sensing electrodes. A CRPSD provides the centroid of the light distribution with a very fast response time (in the order of 10 MHz). Theory predicts that a CRPSD provides very precise measurement of the centroid versus a DRPSD. By precision, we mean *measurement uncertainty*. It depends among other things on the signal to noise ratio and the quantization noise. In practice, precision is important but accuracy is even more important. A CRPSD is in fact a good estimator of the central location of a light distribution.

3.2 DISCRETE RESPONSE POSITION SENSITIVE DETECTORS (DRPSD)

DRPSD on the other hand comprise detectors such as Charge Coupled Devices (CCD) and arrays of photodiodes equipped with a multiplexer for sequential reading. They are slower because all the photo-detectors have to be read sequentially prior to the measurement of the location of the peak of the light distribution. DRPSDs are very accurate because of the knowledge of the distribution but slow. Obviously, not all photo-sensors contribute to the computation of the peak. In fact, what is required for the measurement of the light distribution peak is only a small portion of the total array. Once the pertinent light distribution (after windowing around an estimate around the peak) is available, one can compute the location of the desired peak very accurately.

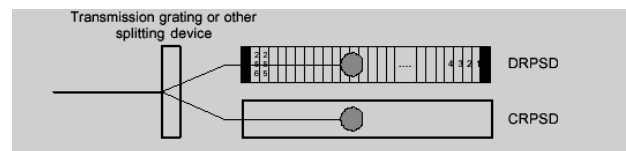

Figure 3(a): In a monochrome system, the incoming beam is split into two components

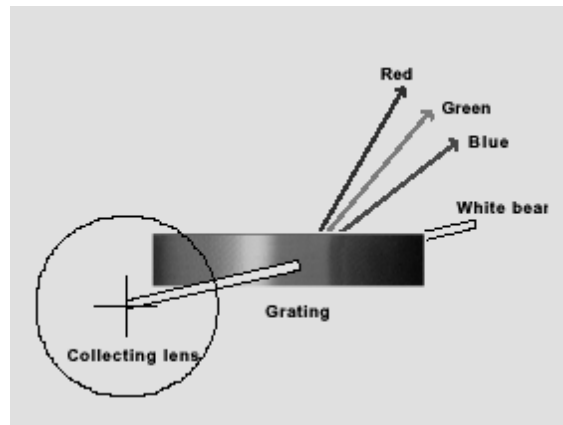

Figure 3(b): artistic view of a smart sensor with color capabilities

Figure 3 shows schematically the new smart position sensor for light spot measurement in the context of 3D and color measurement. In a monochrome range camera, a portion of the reflected radiation upon entering the system is split into two beams (Figure 4a). One portion is directed to a CRPSD that determines the location of the best window and sends that information to the DRPSD.

In order to measure color information, a different optical element is used to split the returned beam into four components, e.g., a diffractive optical element (Figure 3b). The

white zero order component is directed to the DRPSD, while the RGB 1st order components are directed onto three CRPSD, which are used for color detection (Figure 3c). The CRPSDs are also used to find the centroid of the light distribution impinging on them and to estimate the total light intensity. The centroid is computed on chip with the well-known current ratio method i.e. $(I1-I2)/(I1+I2)$ where $I1$ and $I2$ are the currents generated by that type of sensor. The weighed centroid value is fed to a control unit that will select a sub-set (window) of contiguous photo-detectors on the DRPSD. That sub-set is located around the estimate of the centroid supplied by the CRPSD. Then the best algorithms for peak extraction can be applied to the portion of interest.

is directed to the DRPSD, while the RGB 1st order components are directed onto three CRPSD, which are used for color detection. The CRPSDs are also used to find the centroid of the light distribution impinging on them and to estimate the total light intensity. The centroid is computed on chip with the well-known current ratio method i.e. $(I1-I2)/(I1+I2)$ where $I1$ and $I2$ are the currents generated by that type of sensor. [3] The weighed centroid value is fed to a control unit that will select a sub-set (window) of contiguous photo-detectors on the DRPSD. That sub-set is located around the estimate of the centroid supplied by the CRPSD. Then, the best algorithms for peak extraction can be applied to the portion of interest.

4 PROPOSED SENSOR –COLORANGE

4.1 ARCHITECTURE

Figure5 shows the proposed architecture for the colorange chip.

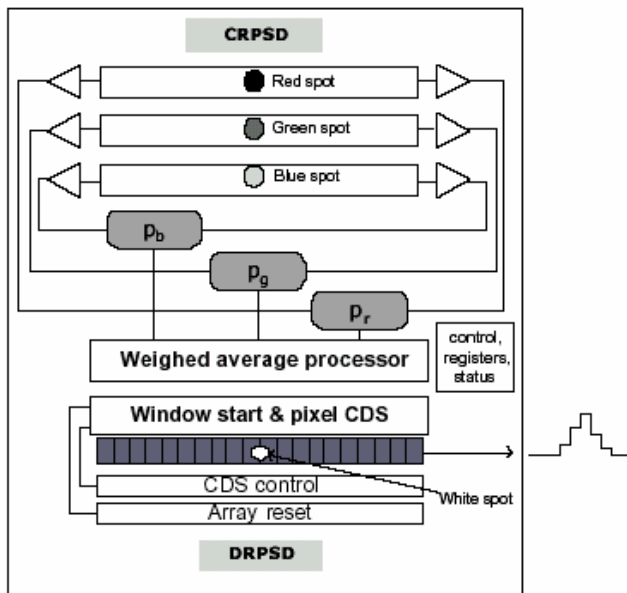

Figure 4(a): The proposed architecture for the colorange chip

An object is illuminated by a collimated RGB laser spot and a portion of the reflected radiation upon entering the system is split into four components by a diffracting optical element as shown in figure 4b. The white zero order component

4.2 32 PIXEL PROTOTYPE CHIP

Figure6 shows the architecture and preliminary experimental results of a first prototype chip of a DRPSD with selectable readout window. This is the first block of a more complex chip that will include all the components.

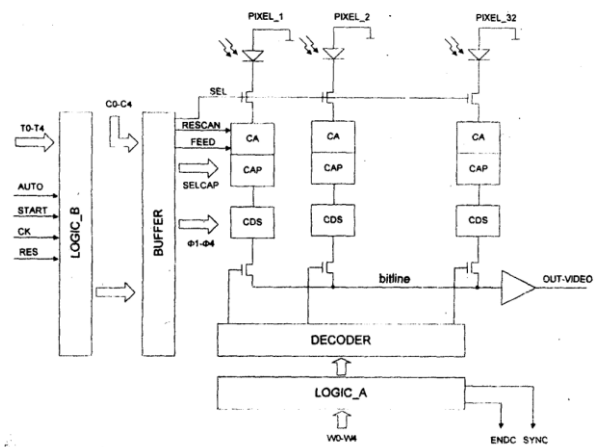

Figure 4(b): Block diagram of the 32-pixel prototype array

The prototype chip consists of an array of 32 pixels with related readout channels and has been fabricated using a 0mm commercial CMOS process. The novelties implemented consist in a variable gain of the readout channels and a selectable readout channels and a selectable readout window of 16 contiguous pixels. Both features are necessary to comply with the requirements of 3D single laser spot sensors, i.e., a linear dynamic range of at least 12 bits and a high 3D data throughput. In the prototype, many of the signals, which, in the final system are supposed to be generated by the CRPSDs, are now generated by means of external circuitry. The large dimensions of the pixel

are required, on one side to cope with speckle noise and, on the other side, to facilitate system alignment. Each pixel is provided with its own readout channel for parallel reading. The channel contains a charge amplifier and a correlated double sampling circuit (CDS). To span 12 bits of dynamic range, the integrating capacitor can assume five different values. In the prototype chip, the proper integrating capacitor value is externally selected by means of external switches C0-C4. In the final sensor, however, the proper value will be automatically set by an on chip circuitry on the basis of the total light intensity as calculated by the CRPSDs.

During normal operation, all 32 pixels are first reset at their bias value and then left to integrate the light for a period of 1ms. Within this time the CRPSDs and an external processing unit estimate both the spot position and its total intensity and those parameters are fed to the window selection logic. After that, 16 contiguous pixels, as addressed by the window selection logic are read out in 5 ms, for a total frame rate of 6ms. Future sensors will operate at full speed, i.e. an order of magnitude faster. The window selection logic LOGIC_A, receives the address of the central pixel of the 16 pixels and calculates the address of the starting and ending pixel. The analog value at the output of each CA within the addressed window is sequentially put on the bit line by a decoding logic, DECODER, and read by the video amplifier. LOGIC-A generates also synchronization and end-of-frame signals which are used from the external processing units. LOGIC_B instead is devoted to the generation of logic signals that derive both the CA and the CDS blocks. To add flexibility also the integration time can be changed by means of the external switches.

5 FEATURES

5.1 ADVANTAGES

- Reduced size and cost.
- Better resolution at a lower system cost.
- High reliability that is required for high accuracy 3D vision systems.

- Complete images of visible surfaces that are rather featureless to the human eye or a video camera can be generated.

5.2 DISADVANTAGES

- The elimination of all stray light in an optical system requires sophisticated techniques.

5.3 APPLICATIONS

- Intelligent digitizers will be capable of measuring accurately and simultaneously color and 3D.
- For the development of hand –held 3D cameras.
- Multi resolution random access laser scanners for fast search and tracking of 3D features.

5.4 FUTURE SCOPE

- Anti-reflecting coating film deposition and RGB filter deposition can be used to enhance sensitivity and for color sensing.

6 CONCLUSION

The results obtained so far have shown that optical sensors have reached a high level of development and reliability those are suited for high accuracy 3D vision systems. The availability of standard fabrication technologies and the acquired know-how in the design techniques, allow the implementation of optical sensors that are application specific: Opto-ASICs.

The trend shows that the use of the low-cost CMOS technology leads competitive optical sensors. Furthermore, post-processing modules, as for example anti reflecting coating film deposition and RGB filter deposition to enhance sensitivity and for color sensing, are at the final certification stage and will soon be available in standard fabrication technologies. The work on the Colo range is being finalized and work has started on a new improved architecture.